

注塑用机械手

TAKE-OUT ROBOT

MBW-130



标准功能 STANDARD FUNCTION

- 装箱动作 (多轴256点)
Packaging motion (Max. 256 points)
- 自由装模点 (115.点 × 2轴)
Free positioning motion (115points × 2stage)
- 取出侧前进姿势控制
Forward and rotate at removing side
- 行走途中姿势
Posture control during traverse
- 落下侧下落途中姿势
Posture midway descent at release side
- 顶针连动
Ejector link
- 不良品排出回路
Defective product reject circuit
- 初期不良品排出回路
Initial defective product reject circuit
- 取出下降停机
Delayed arm descent
- 胶口途中开放 (去程, 返程)
Midway runner release (Move, Revert)
- 水口模内开放
Runner release within mold
- 吸着确认单元 (2回路)
Additional vacuum sensing unit (2 circuit)
- 模行走停机
Delayed traverse
- 溶胶取出回路
Unmelt extract circuit
- 输送带启动信号
Start signal of conveyor
- 内部存储记忆 (最大100种类型)
Internal memory (for Max100 molds)
- 设定值锁定功能
Lock function of setting value
- 固定可动切换
Extraction from fixed mold
- 2国语言切换 (中文, 英文)
Two language exchange (Chinese/English)

型式 MODEL

单位 UNIT

MBW-130

电源 Power Source	V	AC220 ± 10% 50/60Hz
最大消费电力 Max Power Consumption	KW	2.3
使用气压 Air Pressure	Mpa	0.5 ~ 0.7
空气消费量 Air Consumption	Nl/cycle	24
驱动方式 Drive System	---	伺服马达 / AC Servo Motor
姿势 (气缸) Posture (Air Cylinder)	---	90°固定 / 90°Fixed
■ 气缸推力 (气压0.5MPa时) Air Cylinder Driving Force (Air Pressure at 0.5MPa)		
最大可搬重量 Max.Load	Kg	45 [含夹爪重量 / Incl Chuck Weight]
姿势扭矩 Posture Torque	N · m	57.7
■ 行程 Stroke		
主臂上下 Main-arm Vertical	mm	1300/1500
副臂上下 Sub-arm Vertical	mm	---
前后 Crosswise	mm	270 ~ 1280
走行 Traverse	mm	2000/2500
■ 本体重量 Net Weight		
本体 Main Body	Kg	850-880
操作盒 Pendant	Kg	1.6

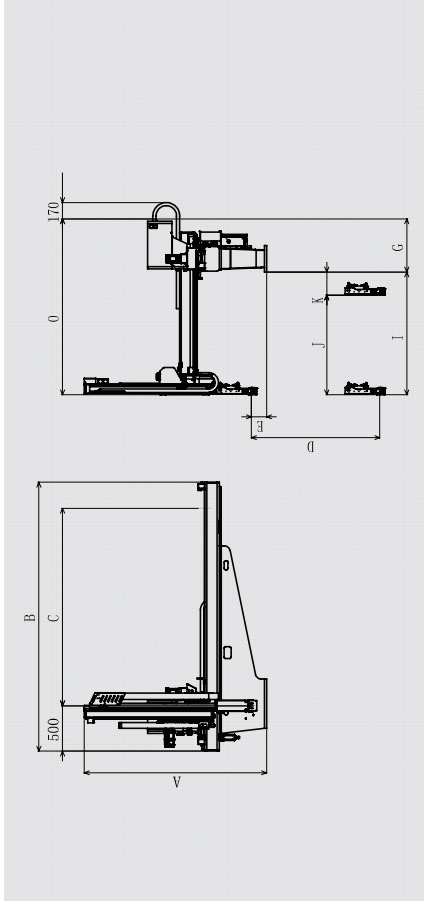

外形尺寸 OUTER DIMENSIONS

MBW-130

A 总高 Overall height	1860(1980)mm
B 总长 Overall length	2725(3205)mm
C 走行行程 Traverse stroke	2000(2500)mm
D 主臂上下行程 Main-arm vertical stroke	1300 (1500) mm
E 主臂上下待机, Main-arm vertical standby	150mm
F 夹具安装有效空间 Bottom of crosswise to chuck mount position	---
G 底座侧面-箱体末端 Base side face-Box end	550
H 副臂上下待机, Sub-arm Vertical standby	---
I 主臂前进最大值 Main-arm reach max	1280mm
J 主臂前进最大行程 Main-arm crosswise stroke max	1010mm
K 主臂前后待机最小值 Main-arm crosswise standby min	270mm
L 主臂接近最小值 Main/Sub-arm proximity min	---
M 副臂前进最大行程 Sub-arm crosswise stroke max	---
N 副臂前后待机最小值 Sub-arm crosswise standby min	---
O 前后箱体末端-箱体末端 Crosswise arm end-Box end	1790

- 当尺寸C是2000mm时, 尺寸B为2725mm
when dimension C is 2000mm, B is 2725mm
- 当尺寸D是1300mm时, 尺寸A为1860mm
when dimension D is 1300mm, A is 1860mm
- 当尺寸C是2500mm时, 尺寸B为3205mm
when dimension C is 2500mm, B is 3205mm
- 当尺寸D是1500mm时, 尺寸A为1980mm
when dimension D is 1500mm, A is 1980mm

选项功能 OPTION FUNCTION

- 夹具内顶刀回路
Air nipper in chuck circuit
- NT顶切·可动侧
NT gate cutting on crossmember of moving
- 吸着确认回路
Additional vacuum sensing unit (4 circuits)
- 制品夹取回路
Product gripping 4 circuits
- 上升途中闭锁
Mold close during ascend
- 回转单元
Rotation unit
- 顶针后退连动
Ejector return link
- 欧洲12
EUROMAP12
- 欧洲67
EUROMAP 67